

# HERZ Integral Fixed Orifice Commissioning Valve

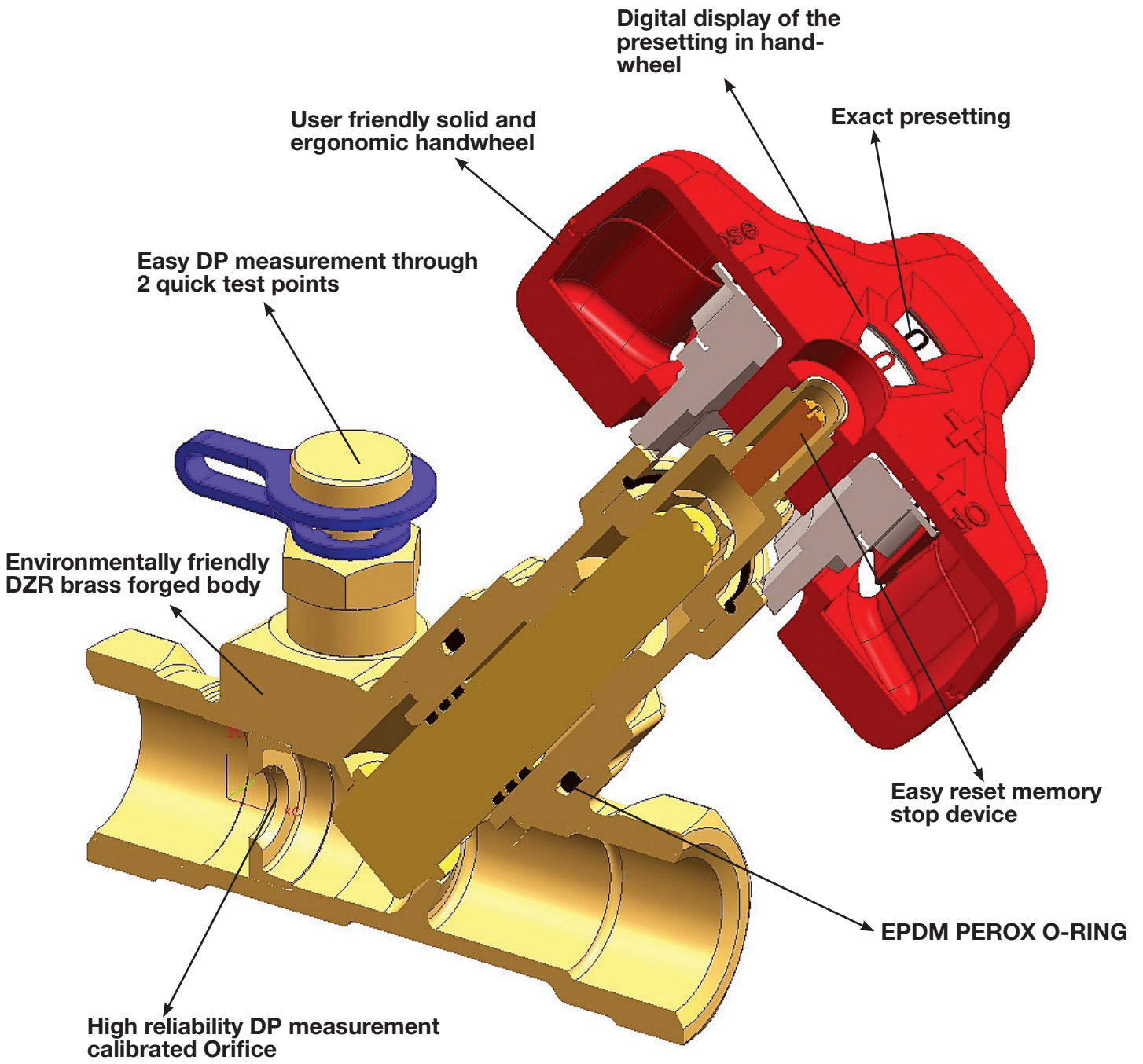





Part of the extensive range of Circuit Balancing valves from Herz. The new Herz 4017 DRZ combined regulating and measuring valve has an integral orifice incorporated into the valve casting. Available in sizes from DN15 to DN50. The valve is also available in Low Flow and Medium Flow DN15 versions.

The commissioning valve has hidden regulating and locking functions with high accuracy and good repeatability.

The valve is fitted with two standard pressure test points, extended test points are available when required.

### Presetting Procedure

1. Set to the desired step according to calculation (digital display on the hand wheel).
2. Remove the hand wheel securing screw
3. Screw the presetting spindle, which is now accessible, in up to the stop.
4. Replace the hand wheel securing screw.

**Max. operating temperature 130 °C (up to DN 32)  
110 °C (from DN 40)**

**Max. operating pressure 20 bar**

### Advantages:

- The flow rate through orifice is constant for all pre-set values, i.e. quick and easy balancing
- Infinitely adjustable presetting, the flow rate which goes through the orifice is precisely controlled
- Through the use of an integrated orifice, the pressure drop is very precisely measurable
- Kv-value of integrated orifice is shown in the descriptive table
- Accuracy  $\pm 5\%$

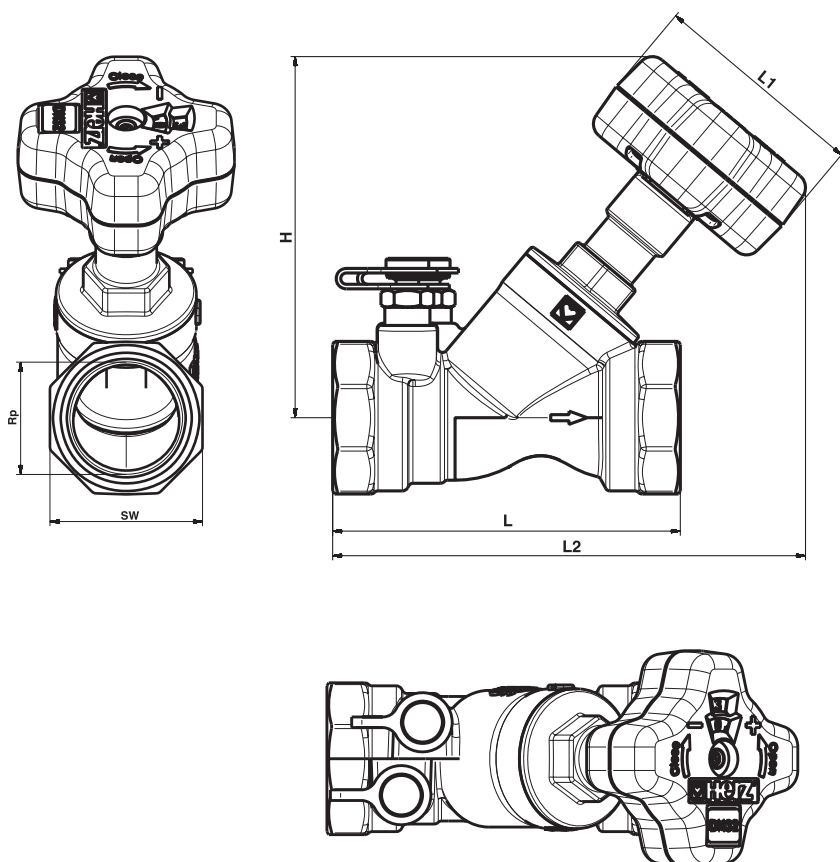

Dimension	Art.-Nr.	L	L1	L2	H	SW 6-kant	SW 8-kant
DN 15 LF	1 4017 11	83	71	130	97	27	-
DN 15 MF	1 4017 21	83	71	130	97	27	-
DN 15	1 4017 01	83	71	130	97	27	-
DN 20	1 4017 02	91	71	135	100	32	-
DN 25	1 4017 03	100	71	145	110	41	-
DN 32	1 4017 04	114	71	155	118	-	50
DN 40	1 4017 05	125	71	168	130	-	55
DN 50	1 4017 06	146	110	191	146	-	70

## STRÖMAX 4017 M

	DN 15 LF	DN 15 MF	DN 15	DN 20	DN 25	DN 32	DN 40	DN 50
<b>Kvs</b>	0,48	0,97	1,95	3,95	7,90	15,75	21,50	46,70
<b>Position of hand-wheel</b>								
<b>0,5</b>	0,05	0,17	0,40	0,33	0,66	0,60	1,10	2,55
<b>1,0</b>	<b>0,07</b>	<b>0,30</b>	<b>0,60</b>	<b>0,63</b>	<b>1,04</b>	1,00	3,10	4,50
<b>1,5</b>	0,14	0,42	0,80	1,20	1,90	<b>2,20</b>	<b>4,80</b>	6,60
<b>2,0</b>	0,22	0,53	1,00	1,70	3,10	3,50	6,30	<b>8,70</b>
<b>2,5</b>	0,29	0,66	1,15	2,25	4,20	4,65	7,90	10,80
<b>3,0</b>	0,35	0,78	1,42	2,80	5,00	5,90	9,50	13,00
<b>3,5</b>	0,41	0,86	1,80	3,25	5,80	7,25	11,20	15,30
<b>4,0</b>	<b>0,46</b>	<b>0,88</b>	<b>2,00</b>	<b>3,60</b>	<b>6,50</b>	8,85	13,00	18,00
<b>4,5</b>	-	-	-	-	-	9,90	14,70	20,20
<b>5,0</b>	-	-	-	-	-	11,40	16,25	22,50
<b>5,5</b>	-	-	-	-	-	12,50	17,40	25,00
<b>6,0</b>	-	-	-	-	-	<b>13,30</b>	<b>18,50</b>	26,70
<b>6,5</b>	-	-	-	-	-	-	-	28,60
<b>7,0</b>	-	-	-	-	-	-	-	30,30
<b>7,5</b>	-	-	-	-	-	-	-	31,90
<b>8,0</b>	-	-	-	-	-	-	-	<b>33,00</b>

**FLOWRATE**

$$Q = \frac{K_{vs} \cdot \sqrt{\Delta p_s}}{36} \quad [l/s]$$

**PRESSURE LOSS in fully open position:**

$$= HLF \cdot \Delta p_s \quad [kPa]$$

**PRESSURE LOSS in fully open position:**

$$= K \cdot \frac{v^2}{2 \cdot g} \quad [mH_2O]$$

**Kvs = Flow coefficient through the pressure test points of the valve**

**Kv = Flow coefficient through the valve**

**HLF = Head loss factor**

**K = Head loss coefficient**

**v = flow velocity**

**g = gravitational constant**

**Δps = differential pressure through the pressure test points of the valve**

## STRÖMAX 4017 M

### Function

Two test points are mounted next to handwheel on the same side of the valve across the integral orifice and factory sealed. This arrangement ensures the best accessibility in any position and optimum connection of measuring instruments.

### Field of application

For isolating and balancing of the cold and hot water systems in buildings or for the adjustment of hydraulic supply-lines.



## STRÖMAX 4017 R

### Function

STRÖMAX-4017-R valves are of the same mechanical design as STRÖMAX-4017-M.

### Field of application

For isolating and balancing of the cold and hot water systems in buildings.



## STRÖMAX 4017 ML

### Function

One standard test point and one test point fitted with a capillary connection are mounted next to handwheel on the same side of the valve across integral orifice and factory sealed. This arrangement ensures the best accessibility in any position and optimum connection of measuring instruments.

### Field of application

For isolating and balancing of the cold and hot water systems in buildings or for the adjustment of hydraulic supply lines.



HERZ- Flow charts

STRÖMAX 4017 M

Art. Nr. **4017**

flow data - flow signal

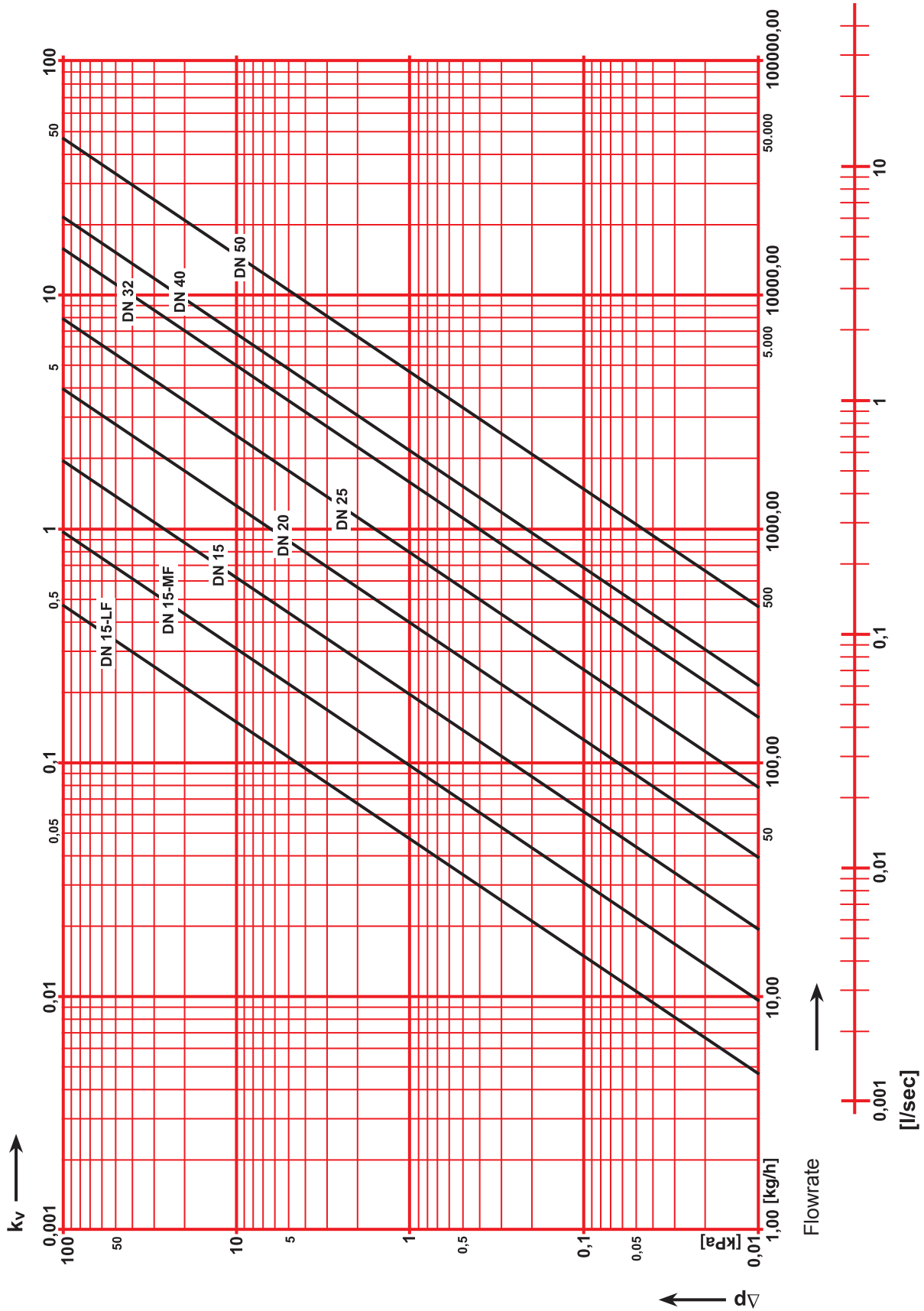

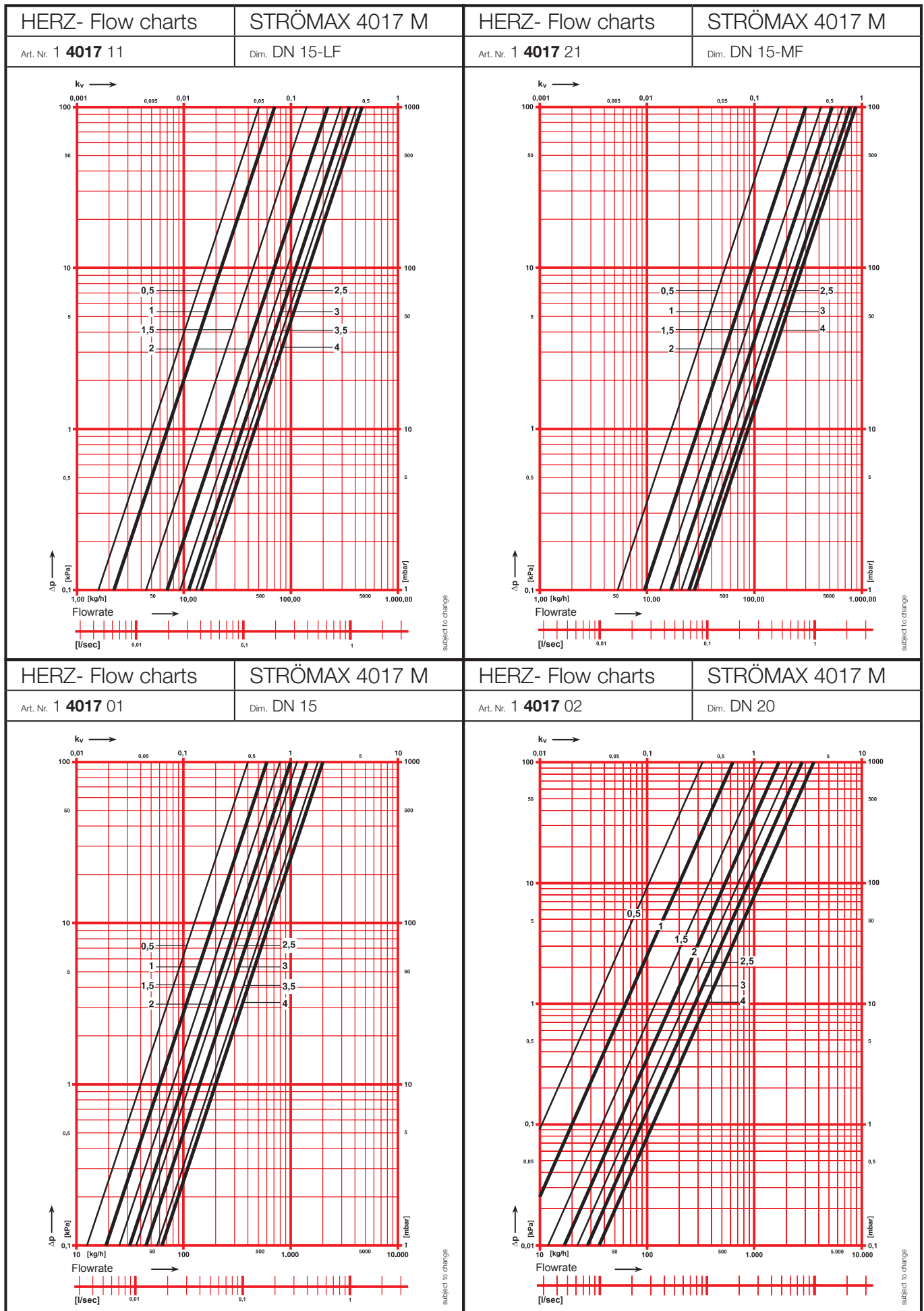



HERZ- Flow charts

STRÖMAX 4017 M

Art. Nr. 1 **4017 03**

Dim. DN 25

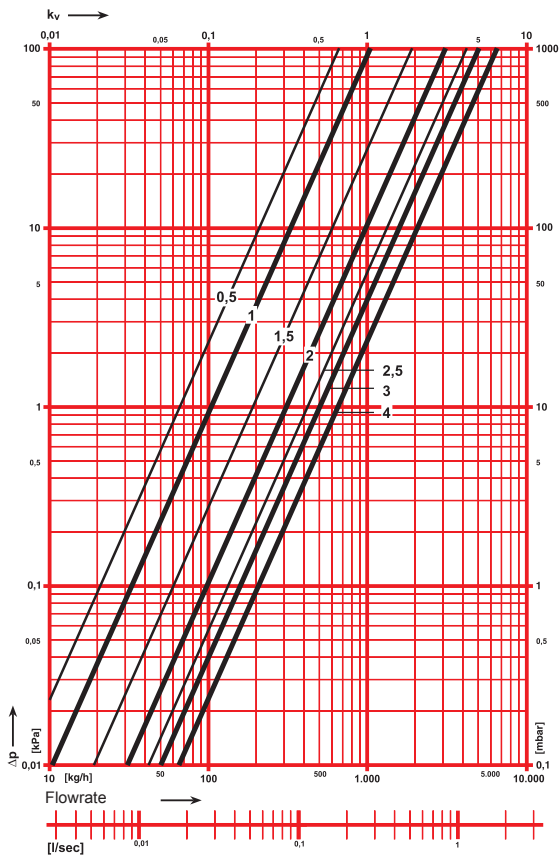

subject to change

HERZ- Flow charts

STRÖMAX 4017 M

Art. Nr. 1 **4017 04**

Dim. DN 32

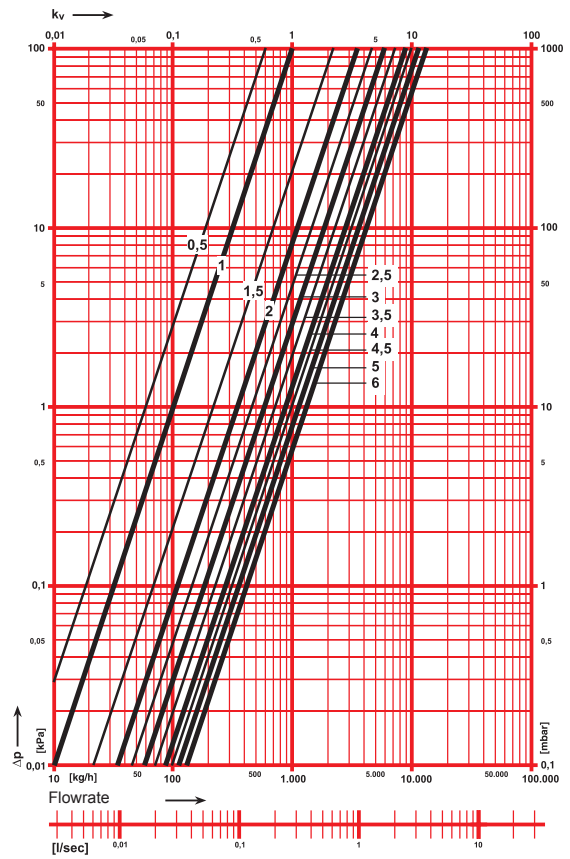

subject to change

HERZ- Flow charts

STRÖMAX 4017 M

Art. Nr. 1 **4017 05**

Dim. DN 40

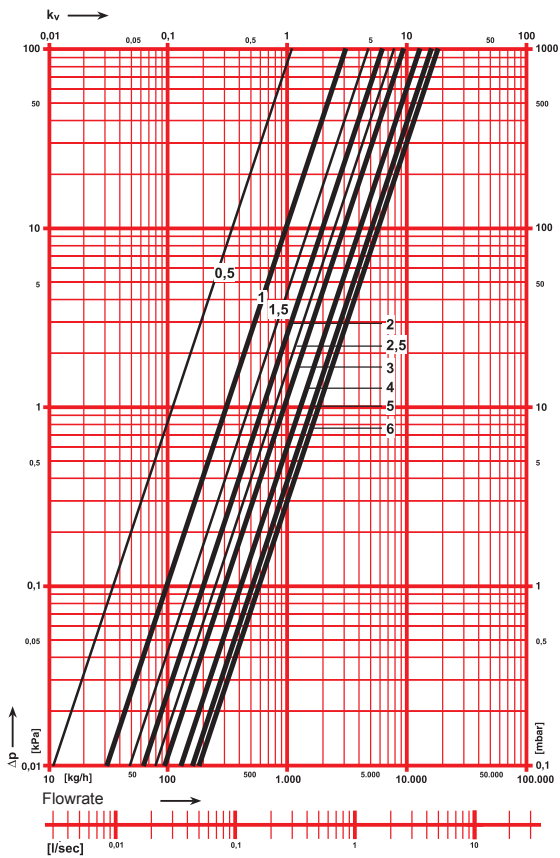

subject to change

HERZ- Flow charts

STRÖMAX 4017 M

Art. Nr. 1 **4017 06**

Dim. DN 50

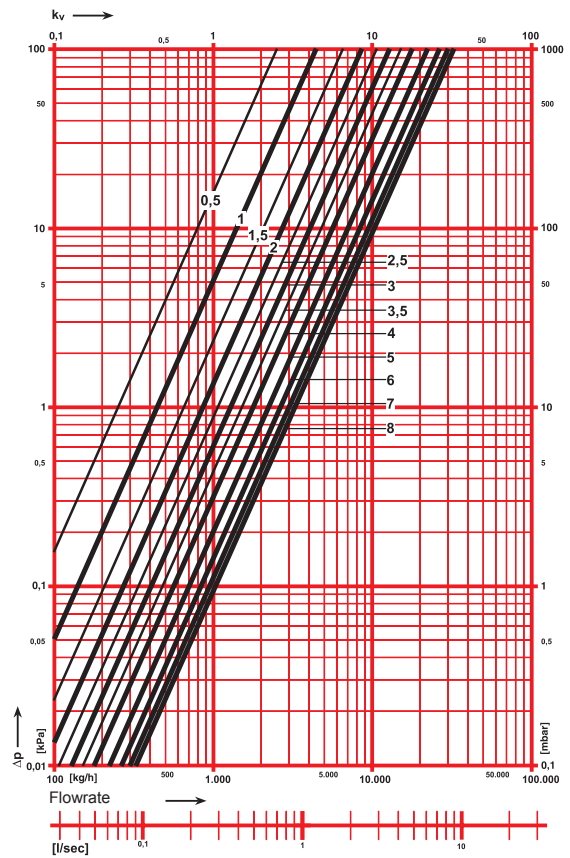

subject to change

**The following points must be considered before commissioning:**

1. The adjustment of a valve in a sub-circuit alters the flow not only in the sub-circuit, but also in other circuits in the system. If such an adjustment reduces the flow in the sub-circuit then the flow elsewhere must increase, as the total mass flow rate is constant.
2. If water flows through a pipe which has a number of branches then the percentage of the total flow in each branch remains constant irrespective of how the total mass flow alters.
3. The initial objective is to obtain the same percentage of the total flow rate in each part of the system (%DFR).
4. Flow is induced into less favoured circuits from favoured circuits.
5. Start with the most favoured branch to induce flow to less favoured branches (greatest %DFR).
6. The index circuit is that circuit displaying the lowest %DFR of the group of circuits on any one branch.
7. Each circuit is balanced against the index circuit starting with the circuit next to the pump and working back to the index.
8. Once all the groups of circuits within branches have been adjusted, the branch valves can be balanced as for the terminals working back towards the index.

**Proportional Balancing with 4017 Fixed Orifice Valves:**

1. With all terminal commissioning valves fully open with the main branch valve fully open and the control valves disabled and fully open, an initial differential pressure reading (signal) is taken at all commissioning valves.
2. The Percentage of Design Flow Rate is then calculated for all (%DFR)







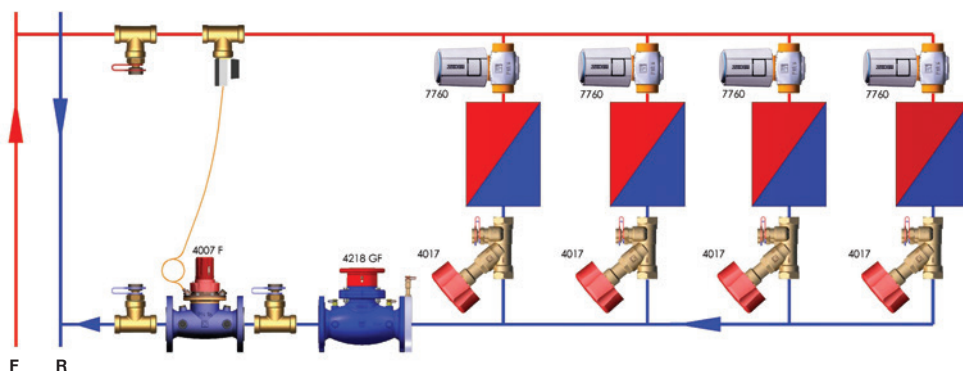



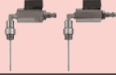

$$\%DFR = 100 \times \sqrt{\frac{\text{Actual Signal } (\Delta P)}{\text{Design Signal } (\Delta P)}}$$

Start with the most favoured branch to induce flow to less favoured branches (greatest %DFR). The index circuit is that circuit displaying the lowest %DFR of the group of circuits on any one branch.



3. Each circuit is balanced against the index circuit starting with the circuit next to the pump and working back to the index.
4. Once all the groups of circuits within branches have been adjusted, the branch valves can be balanced as for the terminals working back towards the index.
5. When using Fixed Orifice the Pressure drop (signal) is used as the measuring unit
6. The formula for establishing the signal to be achieved is
7. Target  $\Delta P = (\text{Index \%DFR}/100)^2 \times \text{Design Signal}$
8. As each valve is regulated, the index %DFR will tend to increase. It is the current value which is used in the reiteration.
9. Identify the index unit of the branch being balanced, this is usually the last measuring point on the branch and will have the lowest %DFR
10. Calculate the target DP signal for the valve with the next lowest %DFR
11. Adjust the regulating valve so that the target signal is achieved within  $\pm 5\%$  of the index %DFR. A further iteration may be required if the circuit being balanced is not within  $\pm 5\%$ .
12. Continue by adjusting the regulating valve for the next terminal nearer the pump until the DFR for this terminal is within  $\pm 5\%$  of the index terminal.
13. Complete the branch, then proceed to the next most favoured branch on the riser and carry out terminal balancing as before.
14. The process is repeated until all branches have been adjusted and balanced proportionally to one another.





			Order number
	<b>Test point adaptors</b>		1 0284 00
	<b>Test point extension</b> 1 Set = 2 Pcs	1/4	1 0284 10
	<b>Test points for HERZ-STRÖMAX-Circuit regulating valves</b> (manufactured from 2004), brass version, blue cap (return) for flow computer.	1/4	1 0284 01
	<b>Test points for HERZ-STRÖMAX-Circuit regulating valves</b> (manufactured from 2004), brass version, red cap (flow) for flow computer.	1/4	1 0284 02
	<b>Test points for HERZ-STRÖMAX-Circuit regulating valves</b> BrassExtended model for insulated valves up to 40mm version, blue cap (return) for flow computer.	1/4	1 0284 11
	<b>Test points for HERZ-STRÖMAX-Circuit regulating valves.</b> Brass version, red cap (flow) for flow computer. Extended model for insulated valves up to 40 mm.	1/4	1 0284 12
	<b>Test points with draining function</b> Brass version, red cap (flow).	1/4	1 0284 22
	<b>Test points with draining function</b> Brass version, blue cap (return).	1/4	1 0284 21
	<b>Test points long version with draining function, blue cap</b>	1/4	1 0284 23
	<b>Test points long version with draining function, red cap</b>	1/4	1 0284 24
	<b>Presetting marker</b> Plastic tag for marking the presetting step. Can be mounted on the valve or pipe.		1 6517 05
	<b>Test points with pulse pipe connection</b> brass version, blue cap (return) for flow computer.	1/4	1 0284 03
	<b>Test points with pulse pipe connection</b> brass version, red cap (flow) for flow computer.	1/4	1 0284 03

#### Suitable actuators for 7217 V

	Order number	Supply voltage	Description	Regulation	Function	Adapter
	1 7990 32	24 V	DDC-actuating drive automatic stroke recognition	0-10 V modulating	modulating normally closed	included
	1 7990 31	24 V	DDC-actuating drive without automatic stroke recognition	0-10 V	modulating normally closed	included
	1 7708 39	230 V	HERZ-actuating drive	2-point or pulse control	normally closed	included
	1 7708 37	230 V	HERZ-actuating drive	2-point or pulse control with end switch	normally closed	included
	1 7708 31	230 V	HERZ-actuating drive	2-point or pulse control	normally open	included
	1 7711 01	230 V	HERZ-actuating drive	2-point or pulse control	normally closed	included
	1 7711 10	230 V	HERZ-actuating drive	2-point or pulse control	normally closed	included
	1 7711 11	230 V	HERZ-actuating drive	2-point or pulse control	normally open	included
	1 7711 12	24 V	HERZ-actuating drive	2-point or pulse control	normally closed	included
	1 7711 13	24 V	HERZ-actuating drive	2-point or pulse control	normally open	included

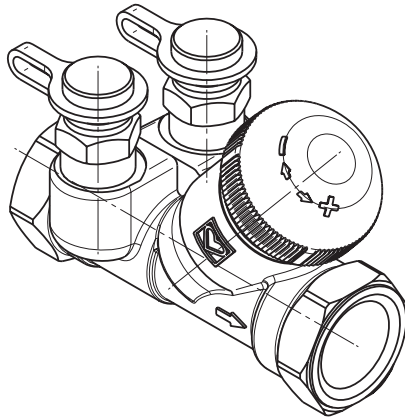
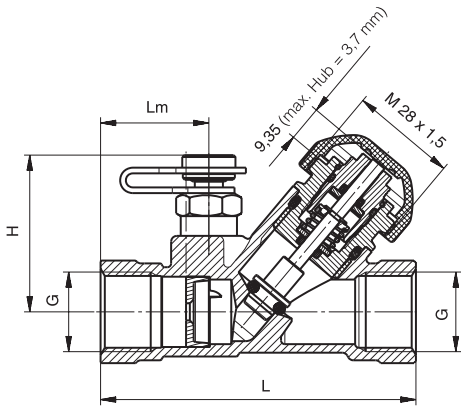

STRÖMAX	Art.Nr.	DN	L	Lm	Rp	H	SW	kv	kvs of the orifice
TS-V	1 7217 51	15	83	28,5	1/2	41	27	0,45 - 1,70	1,95
TS-V LF	1 7217 50	15	83	28,5	1/2	41	27	0,07 - 0,45	0,48
TS-V MF	1 7217 59	15	83	28,5	1/2	41	27	0,30 - 0,90	0,97
TS-V	1 7217 52	20	91	31	3/4	41	32	0,40 - 3,40	3,95

Presetting	Turns
0	0
1	1/2
2	1
3	1 ½
4	2
5	2 ½
6	3

Max Temperature **130 °C**  
 Pressure Rating **20 bar**

### Function

7217 STRÖMAX-TS-V with integrated orifice, DN 15-20, inclined model, brass version, body made of DZR brass, female thread connection, with thermostat TS-V, M 28 x 1.5 thread connection, with orange cap. Self-sealing by means of O-Ring; 2 test points (0284) are mounted across the integral orifice.

### Field of application

Domestic equipment with cold and hot water, zone control. For hydraulic balancing in hot or cold equipment, control of distribution pipes, circuits, heat exchangers and hot and cold terminals.

DN	15	15-LV	15-MF	20
Position	kv	kv	kv	kv
0,0	0,40	0,07	0,17	0,33
1,0	0,60	0,15	0,30	0,80
2,0	0,80	0,23	0,42	1,70
3,0	1,00	0,31	0,53	2,40
4,0	1,15	0,36	0,66	2,80
5,0	1,80	0,41	0,78	3,10
6,0	2,00	0,45	0,88	3,40

1	4017 R
2	4002
3	4017 M
4	4113
5	7217 TS-V
6	7011
7	2414
8	7791

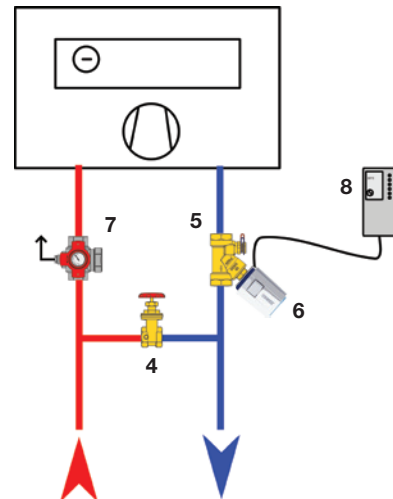
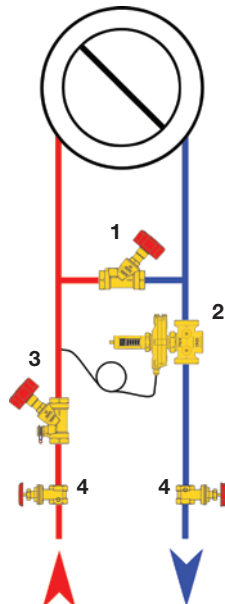

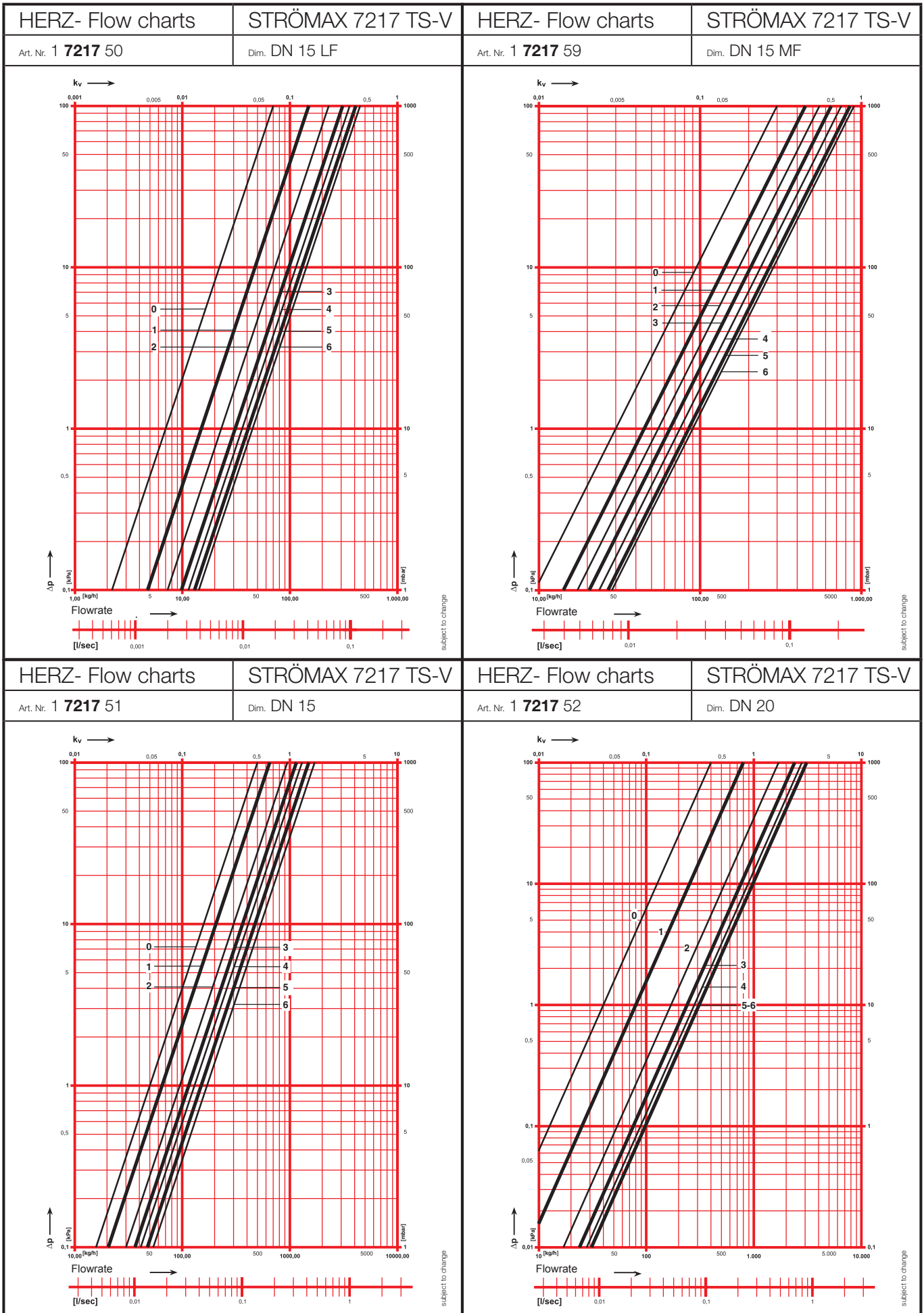



**HERZ Valves UK**

Progress House, Moorfield Point  
Moorfield Road, Slyfield Industrial Estate  
Guildford, Surrey GU1 1RU  
Telephone: +44 (0)1483 502211, Fax: +44 (0)1483 502025  
E-Mail: [sales@herzvalves.com](mailto:sales@herzvalves.com)  
[www.herzvalves.com](http://www.herzvalves.com)

**International headquarter**

**HERZ Armaturen GmbH**

Richard-Strauss-Str. 22, A-1230 Vienna  
Tel.: +43 (0)1 616 26 31-0, Fax: +43 (0)1 616 26 31-227  
E-Mail: [office@herz.eu](mailto:office@herz.eu)

[www.herz.eu](http://www.herz.eu)

